

F-1522SCEN

PANEL CONE SPEAKER

The F-1522SC ceiling and wall-mounted speaker covers an extremely wide area and can be used for 25, 70 and 100 V line applications. Well-balanced sound can be heard uniformly at any location.



Order no: F-1522SCEN Q F00
Alternative products: F-2352SCEN

Specifications

Frequency response	45 Hz - 20 kHz (peak -20 dB)
Connection	Push-in connector (Bridging terminal 2 branch type)
Sensitivity (1#V, 1#m)	88 dB
Speaker component	10 cm cone-type
Rated input (High Impedance)	6 W
Tappings	100 V: 1.7 Ω (6 W) / 3.3 Ω (3 W) 70 V: 830 Ω (6 W), 1.7 Ω (3 W) / 3.3 Ω (1.5 W)
Mounting hole	135,00 mm
Rated impedance	8 Ω
Rated Input (Low Impedance)	Continuous pink noise: 9 W, Continuous program: 18 W
Dimensions (W x H x D)	x 117
Dimensions (ø x D)	155 x 117 mm
Finish	Fire-resistant ABS resin (resin material grade: UL-94 V-0), paint, white Punched net: Steel plate, paint, white Dust-proof bag: Artificial fiber, black

F-1522SCEN

PANEL CONE SPEAKER

Appearance

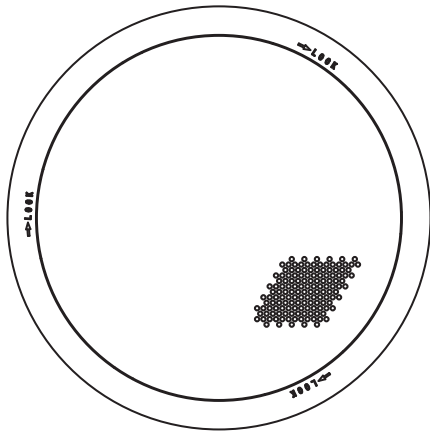

Front View

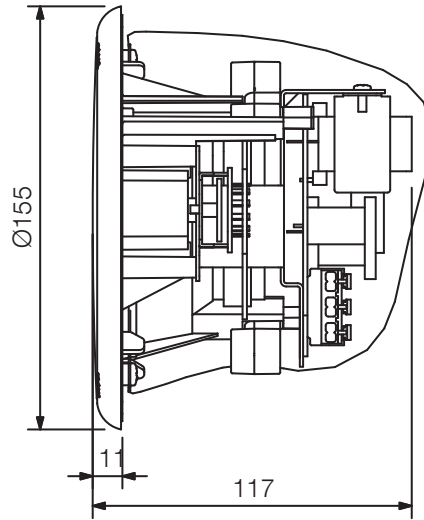

Side View

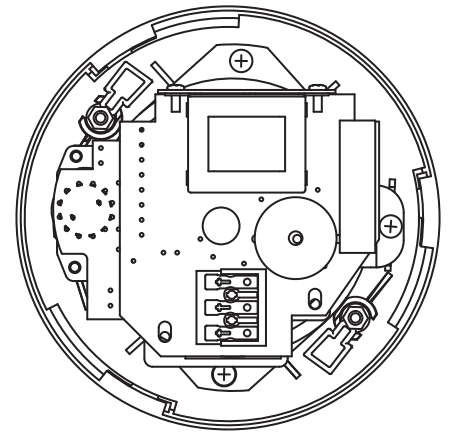

Rear View

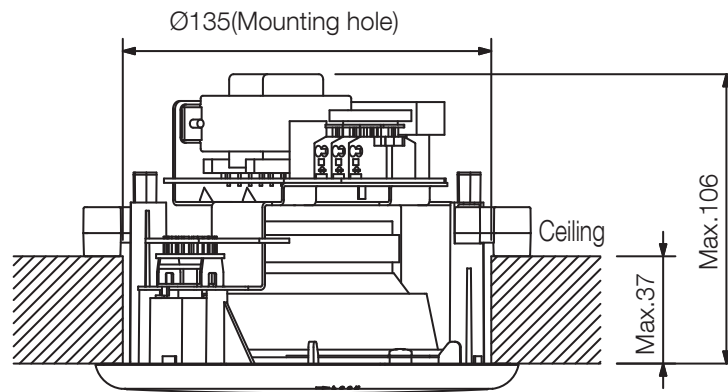

Ceiling mounting

UNIT:mm

SCALE:1/3